

Armador: _____
 Teléfono: _____

Nombre: _____
 N° de vela: _____
 Modelo: _____
 Pies: _____
 Colores: _____

Tipo de vela:	
<input type="radio"/> Mayor	<input type="checkbox"/>
<input type="radio"/> Mayor enrollable	<input type="checkbox"/>
<input type="radio"/> Génova	<input type="checkbox"/>
<input type="radio"/> Génova enrollable	<input type="checkbox"/>
<input type="radio"/> Trinquetta	<input type="checkbox"/>
<input type="radio"/> Spi	<input type="checkbox"/>
<input type="radio"/> Spi asimétrico	<input type="checkbox"/>
<input type="radio"/> Otra _____	<input type="checkbox"/>

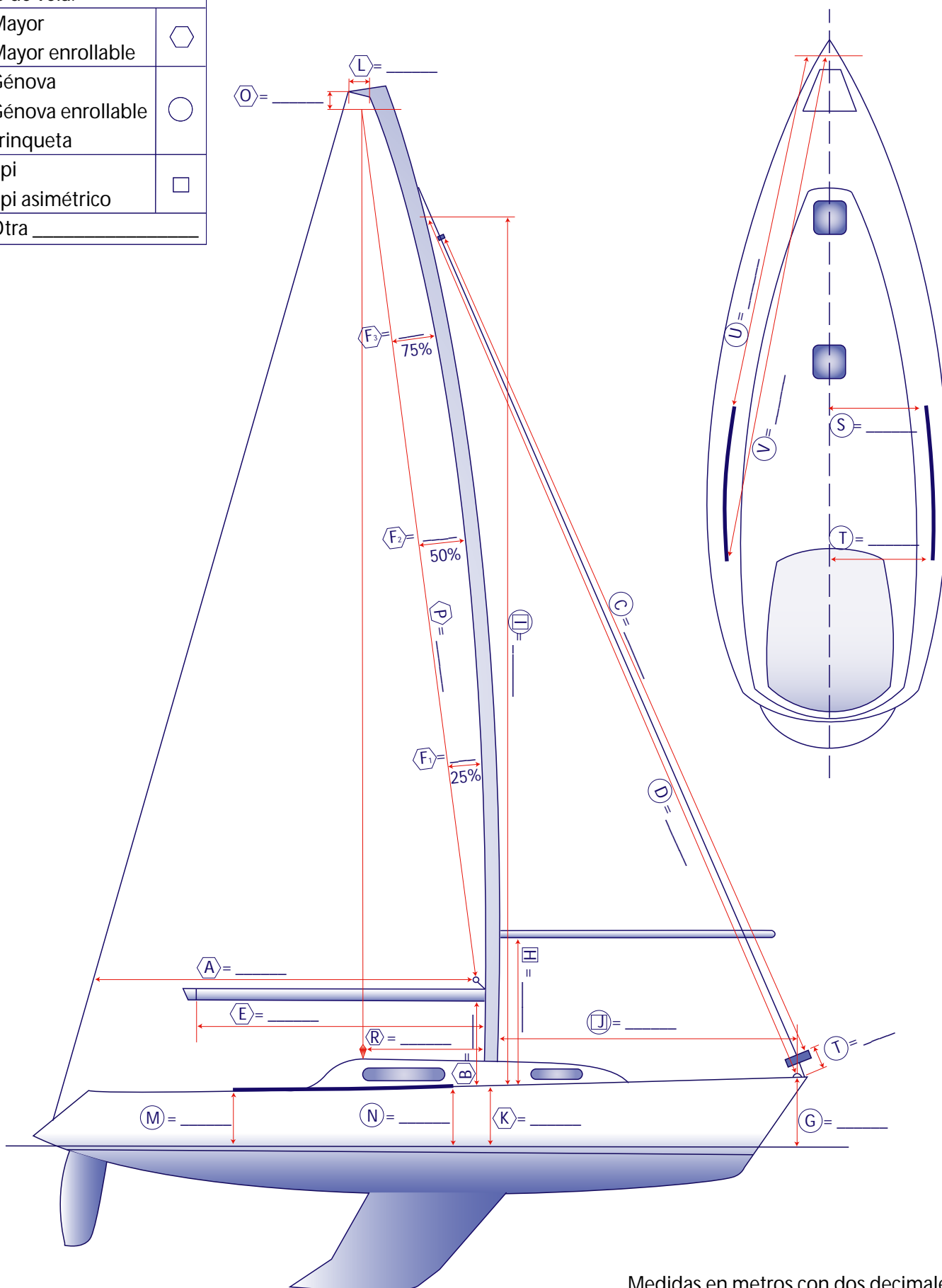

Medidas en metros con dos decimales